

GCAN-PLC

GCAN-PLC-326-E/R

User manual



Contents

1. Introduction	3
1.1 Overview	3
1.2 Model comparison and performance characteristics	3
1.3 Typical application	4
2. Installation and usage	5
2.1 Module Appearance	5
2.2 Module interface definition	5
2.2.1 Port0 interface	5
2.2.2 Port1 interface	6
2.2.3 DI terminal block interface	7
2.2.4 Terminal block wiring instructions	8
2.2.5 DO terminal block interface	9
2.2.6 DO terminal block wiring instructions	10
2.2.7 AI, AO terminal block interface	11
2.3 System status indicator	12
3. Communication Connection	15
3.1 Serial connection	15
3.2 CAN connection	15
3.3 CAN bus terminal resistance	16
4. PLC program running switch and reset button	17
5. Technical specifications	18
Sales and service	19

1. Introduction

1.1 Overview

GCAN-PLC-326-E/R series is a programmable logic controller integrated with bus control function. It not only has the characteristics of simple appearance and high cost performance, but also can be easily connected to CAN bus system and Modbus system.

GCAN-PLC-326-E/R series products combine microprocessor, integrated power supply, input circuit and output circuit into a compact housing to form a powerful PLC. Once the user program is downloaded, the PLC will contain the logic needed to monitor the input and output devices in the application.

GCAN-PLC-326-E/R series can be programmed with OpenPCS software, which supports five standard programming languages specified in the IEC-61131-3 standard, which makes the program highly portable and reusable , and the software also has a variety of debugging functions (breakpoint, single step, etc.), which makes debugging programs more convenient

GCAN-PLC -326-E/R series can not only complete various digital/analog input/output, but also integrates a variety of commonly used industrial field buses, such as: CAN bus, RS485 bus, Ethernet bus, and supports common Communication protocols such as: CANopen, Modbus RTU, Modbus TCP, etc.

1.2 Model comparison and performance characteristics

Module	GCAN-PLC-326-E	GCAN-PLC-326-R
Power supply	24V DC	24V DC
CAN	1	1
RS485	2	2
Ethernet	1	1
DI(PNP)	24	24
DO(PNP)	16	/
Relay outout	/	16
AI	2 0~10V, 16bit	2 0~10V, 16bit
AO	2 0~20mA, 12bit	2 0~20mA, 12bit
High-speed counter input	3 (Multiplexed with DI3/4/5)	3 (Multiplexed with DI3/4/5)

High-speed PWM output	2 (multiplexed with DO0/1)	/
Canopen master/slave	Support	Support
Modbus RTU master/slave	Support	Support
Modbus TCP master/slave	Support	Support
Working temperature	(-40°C~+85°C)	(-40°C~+85°C)
Protection degree	IP20	IP20

1.3 Typical application

- Industrial automation control core
- Analog closed-loop control system
- Switch value open-loop control, logic operation
- Industrial CAN bus, ModBUS bus network communication

2. Installation and usage

This chapter introduces the method installation and wiring, the meaning of the indicator and the interface.

2.1 Module Appearance

The appearance of GCAN-PLC-326-E/R series controller is shown in Figure 2.1. This series contains 2 DB9 interfaces (port0 is DB9 male, port1 is DB9 female), one RJ45 interface. Among them, port0 is 1 channel of CAN interface, its pin definition is shown in 2.2.1, port1 is 2 channels of RS485 interface, its pin definition is shown in 2.2.2, the RJ45 interface is an Ethernet interface, which can be used for Ethernet communication and controller programming,

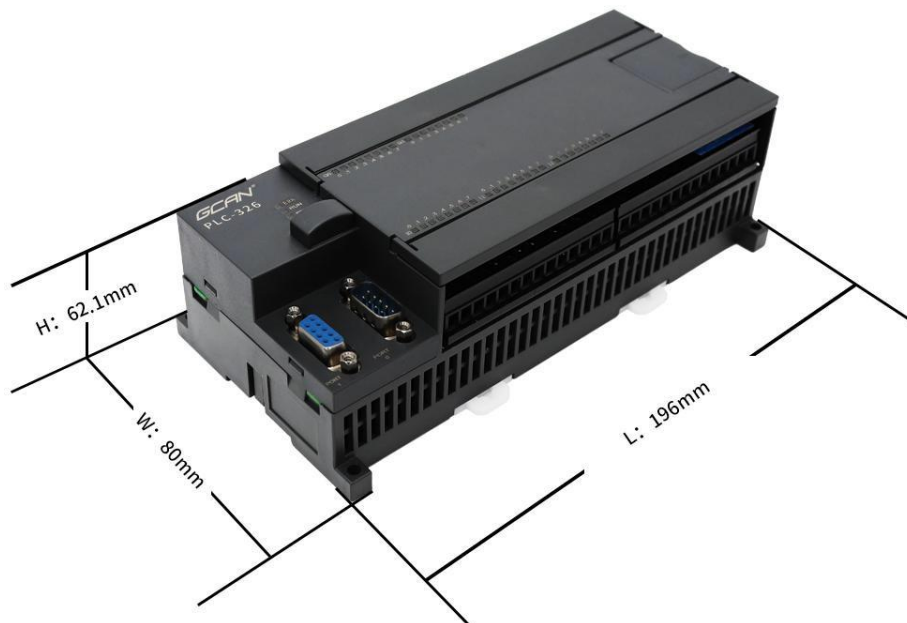

Figure 2.1 Appearance of GCAN-PLC-326E/R

2.2 Module interface definition

2.2.1 Port0 interface

The PORT0 interface of the main control module of the GCAN-PLC-326E/R series is a DB9 male interface, which includes a CAN communication interface,

The pin definition is as shown in the figure and the table below (Note: the pins not written in the table are all NC)

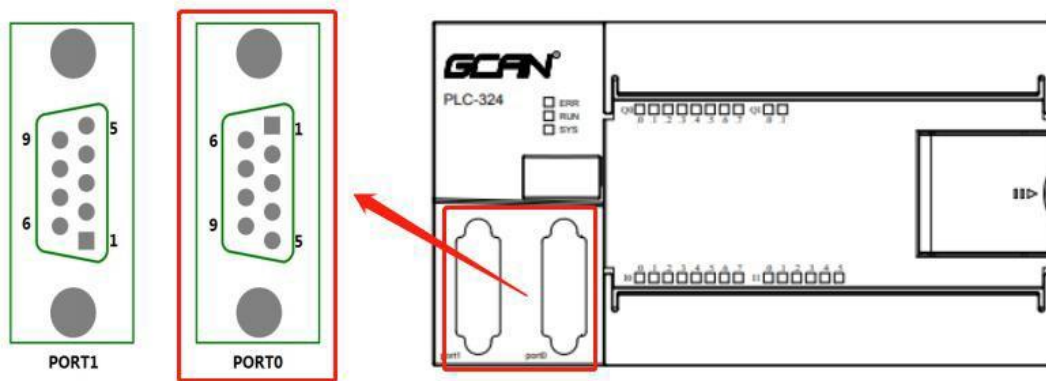

Figure 2.2 PORT0, PORT1 interface of GCAN-PLC-326E/R series

PORT0 serial number	Meaning
2	CAN_L
3	GND
5	PE
6	GND
7	CAN_H

Table 2.1 PORT0 interface definition of GCAN-PLC-326E/R series

2.2.2 Port1 interface

The PORT1 interface of the main control module of the GCAN-PLC-326E/R series is a DB9 female interface, which includes two 485 communication interfaces, The pin definition is as shown in the figure and table below (Note: the pins not written in the table are all NC).

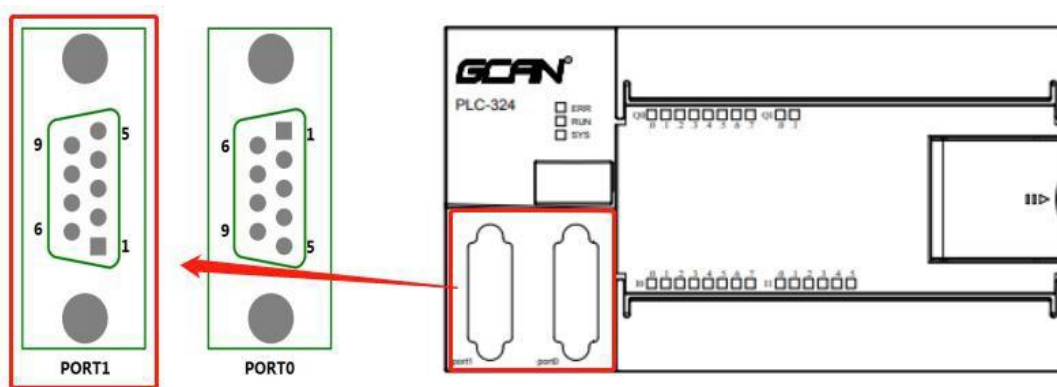

Figure 2.3 PORT0, PORT1 interface of GCAN-PLC-326E/R series

PORT1 serial number	Meaning
1	Second channel 485_A2
3	First channel 485_A1
4	PE
6	Second channel 485_B2
7	PE
8	First channel 485_B1

Table 2.2 PORT1 interface definition of GCAN-PLC-326E/R series

2.2.3 DI terminal block interface

The main control module of GCAN-PLC-326E/R series contains upper and lower two rows of terminal blocks, and the lower terminal block is DI terminal block, respectively I0.0~I0.7, I1.0~I1.4, I1.5~I1.7, I2.0~I2.7, a total of 24 digital input points, where DI3~DI5 are multiplexed for PNP digital input and high-speed counting input, and a set of DC 24V power output (not DO output), as shown in the figure.

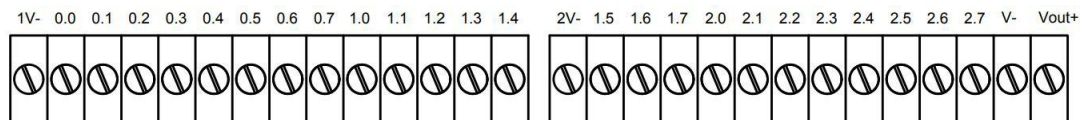

Figure 2.4 DI terminal block interface of GCAN-PLC-326E/R series

DI side terminal name	Meaning
1V-	DI0~DI12 common terminal
0.0	DI0-Configuration address I0.0
0.1	DI1-Configuration address I0.1
0.2	DI2-Configuration address I0.2
0.3	DI3-Configuration address I0.3
0.4	DI4-Configuration address I0.4
0.5	DI5-Configuration address I0.5
0.6	DI6-Configuration address I0.6
0.7	DI7-Configuration address I0.7
1.0	DI8-Configuration address I1.0
1.1	DI9-Configuration address I1.1
1.2	DI10-Configuration address I1.2
1.3	DI11-Configuration address I1.3
1.4	DI12-Configuration address I1.4
2V-	DI13~DI23 common terminal
1.5	DI13-Configuration address I1.5

1.6	DI14-Configuration address I1.6
1.7	DI15-Configuration address I1.7
2.0	DI16-Configuration address I2.0
2.1	DI17-Configuration address I2.1
2.2	DI18-Configuration address I2.2
2.3	DI19-Configuration address I2.3
2.4	DI20-Configuration address I2.4
2.5	DI21-Configuration address I2.5
2.6	DI22-Configuration address I2.6
2.7	DI23-Configuration address I2.7
V-	DC 24V Power output negative
Vout+	DC 24V Power output positive

Table 2.3 GCAN-PLC-326E/R series DI side terminal block interface definition

When DI3~DI5 are used as high-speed counting inputs, their configuration addresses are shown in the table below.

Interface definition	Meaning	length
DI3	The first channel counting input value - configuration address I20.0	4bytes
	The first channel counting input frequency - configuration address I24.0	4bytes
DI4	The second channel counting input value - configuration address I28.0	4bytes
	The second channel counting input frequency - configuration address I32.0	4bytes
DI5	The third channel counting input value - configuration address I36.0	4bytes
	The third channel counting input frequency - configuration address I40.0	4bytes

Table 2.4 GCAN-PLC-326E/R series high-speed counting input configuration definition

2.2.4 Terminal block wiring instructions

GCAN-PLC-326E/R series main control module DI terminal block wiring method is as shown in the figure, the input common terminals of DI0~DI12 are all connected to 1V-, and the input common terminals of DI13~DI23 are connected to 2V-, the wiring diagram in the figure Take DI as an example of PNP digital input.

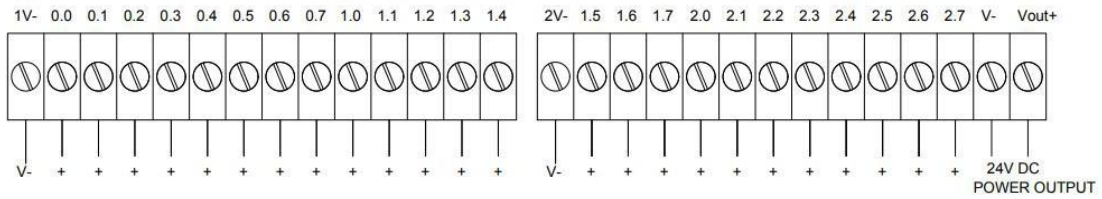

Figure 2.4 DI wiring diagram of GCAN-PLC-326E/R series

2.2.5 DO terminal block interface

The main control module of GCAN-PLC-326E/R series contains upper and lower two rows of terminal blocks. The upper terminal block contains an RJ45 interface and DO terminal block. The DO terminal blocks are Q0.0~Q0.7, Q1.0~Q1.7. There are 16 digital output points in total, among which DO0 and DO1 are multiplexing interfaces for PNP digital output and PWM high-speed pulse output, as well as the power supply interface, And 4 common terminals of output points, two 1C are common terminals of Q0.0~Q0.7, and two 2C are common terminals of Q1.0~Q1.7. To prevent excessive heating, each common terminal Connect 2 pins, the interface definition is as shown in the figure.

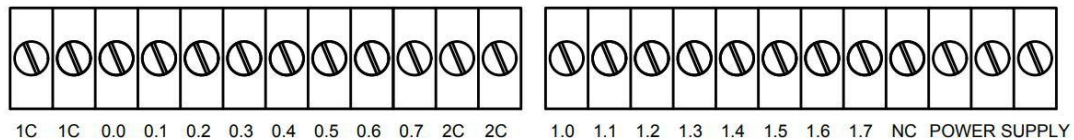

Figure 2.5 DO terminal block interface of GCAN-PLC-326E/R series

DO side terminal name	Meaning
1C	DO0~DO7 common terminals
1C	
0.0	DO0-Configuration address Q0.0
0.1	DO1-Configuration address Q0.1
0.2	DO2-Configuration address Q0.2
0.3	DO3-Configuration address Q0.3
0.4	DO4-Configuration address Q0.4
0.5	DO5-Configuration address Q0.5
0.6	DO6-Configuration address Q0.6
0.7	DO7-Configuration address Q0.7
2C	DO8~DO15 common terminals
2C	

1.0	DO8-Configuration addressQ1.0
1.1	DO9-Configuration addressQ1.1
1.2	DO10-Configuration addressQ1.2
1.3	DO11-Configuration addressQ1.3
1.4	DO12-Configuration addressQ1.4
1.5	DO13-Configuration addressQ1.5
1.6	DO16-Configuration addressQ1.6
1.7	DO17-Configuration addressQ1.7

Table 2.5 GCAN-PLC-326E/R series DO side terminal block interface definition

When DO0 and DO1 are used as PWM high-speed pulse output, their configuration addresses are shown in the table below.

Interface definition	Meaning	length
DO0	The first channel pulse output frequency - configuration address Q20.0	4bytes
	The first channel pulse output speed - configuration address Q24.0	2bytes
DO1	The first channel pulse output frequency - configuration address Q26.0	4bytes
	The first channel pulse output speed - configuration address Q30.0	2bytes

Table 2.6 GCAN-PLC-326E/R series PWM high-speed pulse output configuration definition

2.2.6 DO terminal block wiring instructions

The DO terminal block wiring method of GCAN-PLC-326E/R series main control module is shown in the figure. The output common terminal of DO0~DO7 is 1C, and the output common terminal of DO8~DO15 is 2C. To prevent excessive heating, each common terminal Connect 2 pins, The wiring diagrams in the figure all take DO as a PNP digital output as an example

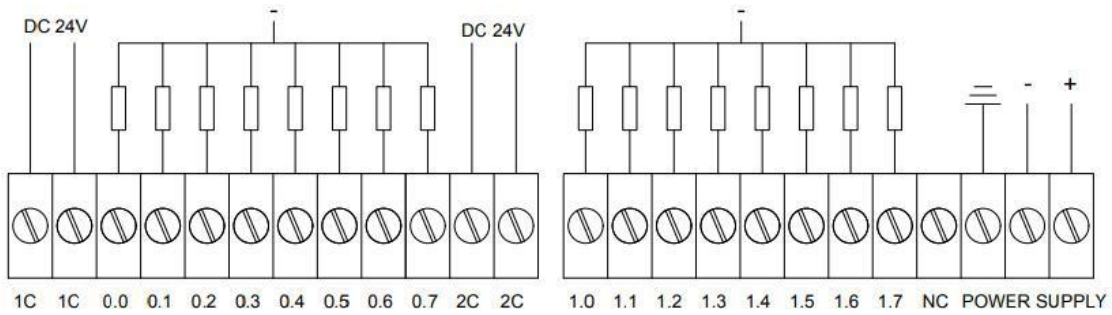

Figure 2.6 DO wiring diagram of GCAN-PLC-326E/R series

2.2.7 AI, AO terminal block interface

The main control module of GCAN-PLC-326E/R series contains an Ethernet interface and a set of analog interface terminal blocks, as shown in the figure.

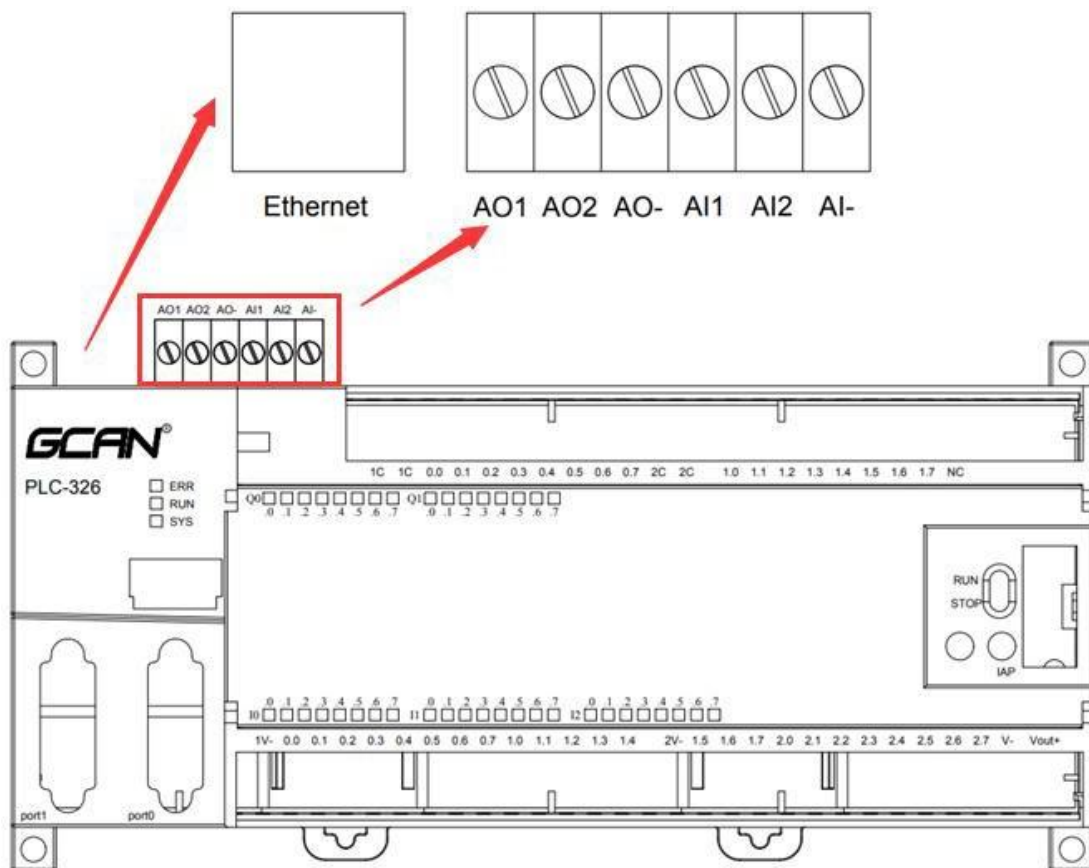
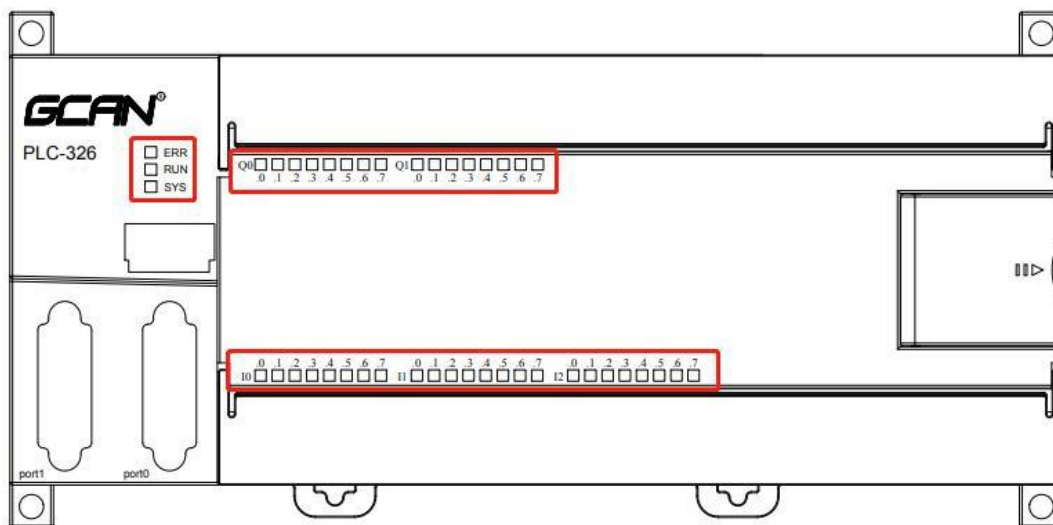

Figure 2.7 AI/AO terminal diagram of GCAN-PLC-326E/R series

AI/AO Terminal name	Meaning	length
AO1	The first channel analog output positive - configuration address Q4.0	2bytes
AO2	The second channel analog output positive - configuration address Q6.0	2bytes
AO-	Analog output negative	-
AI1	The first channel analog input positive - configuration address I4.0	2bytes
AI2	The second channel analog input positive - configuration address I6.0	2bytes
AI-	Analog input negative	-

2.3 System status indicator

GCAN-PLC-326E/R series has three groups of indicator lights, system status indicator, DI status indicator and DO status indicator.



System Status Indicator	color	Status	status meaning
ERR	red	not bright	no error
		bright	run error
RUN	green	not bright	User program is not running
		flashing	user program running
SYS	green	flashing	The system is running normally
		other	system error

Table 2.5 Definition of GCAN-PLC-326E/R Series System Indicators

DI Status Indicator	color	Status	status meaning
I0.0	green	not bright	DI0 no input
		bright	DI0 input logic 1
I0.1	green	not bright	DI1 no input
		bright	DI1 input logic 1
I0.2	green	not bright	DI2 no input
		bright	DI2 input logic 1
I0.3	green	not bright	DI3 no input
		bright	DI3 input logic 1
I0.4	green	not bright	DI4 no input
		bright	DI4 input logic 1
I0.5	green	not bright	DI5 no input
		bright	DI5 input logic 1
I0.6	green	not bright	DI6 no input
		bright	DI6 input logic 1

I0.7	green	not bright	DI7 no input
		bright	DI7 input logic 1
I1.0	green	not bright	DI8 no input
		bright	DI8 input logic 1
I1.1	green	not bright	DI9 no input
		bright	DI9 input logic 1
I1.2	green	not bright	DI10 no input
		bright	DI10 input logic 1
I1.3	green	not bright	DI11 no input
		bright	DI11 input logic 1
I1.4	green	not bright	DI12 no input
		bright	DI12 input logic 1
I1.5	green	not bright	DI13 no input
		bright	DI13 input logic 1
I1.6	green	not bright	DI14 no input
		bright	DI14 input logic 1
I1.7	green	not bright	DI15 no input
		bright	DI15 input logic 1
I2.0	green	not bright	DI16 no input
		bright	DI16 input logic 1
I2.1	green	not bright	DI17 no input
		bright	DI17 input logic 1
I2.2	green	not bright	DI18 no input
		bright	DI18 input logic 1
I2.3	green	not bright	DI19 no input
		bright	DI19 input logic 1

I2.4	green	not bright	DI20 no input
		bright	DI20 input logic 1
I2.5	green	not bright	DI21 no input
		bright	DI21 input logic 1
I2.6	green	not bright	DI22 no input
		bright	DI22 input logic 1
I2.7	green	not bright	DI23 no input
		bright	DI23 input logic 1

Table 2.6 GCAN-PLC-326E/R series DI indicator definition

DO Status Indicator	color	Status	status meaning
Q0.0	green	not bright	DO0 no output
		bright	DO0 output logic 1
Q0.1	green	not bright	DO1 no output
		bright	DO1 output logic 1
Q0.2	green	not bright	DO2 no output
		bright	DO2 output logic 1
Q0.3	green	not bright	DO3 no output
		bright	DO3 output logic 1
Q0.4	green	not bright	DO4 no output
		bright	DO4 output logic 1
Q0.5	green	not bright	DO5 no output
		bright	DO5 output logic 1
Q0.6	green	not bright	DO6 no output
		bright	DO6 output logic 1
Q0.7	green	not bright	DO7 no output
		bright	DO7 output logic 1
Q1.0	green	not bright	DO8 no output
		bright	DO8 output logic 1
Q1.1	green	not bright	DO9 no output
		bright	DO9 output logic 1
Q1.2	green	not bright	DO10 no output
		bright	DO10 output logic 1
Q1.3	green	not bright	DO11 no output
		bright	DO11 output logic 1
Q1.4	green	not bright	DO12 no output
		bright	DO12 output logic 1
Q1.5	green	not bright	DO13 no output
		bright	DO13 output logic 1
Q1.6	green	not bright	DO14 no output
		bright	DO14 output logic 1

Q1.7	green	not bright	DO15 no output
		bright	DO15 output logic 1

Table 2.7 GCAN-PLC-326E/R series DO indicator definition

3. Communication Connection

3.1 Serial connection

GCAN-PLC-326E/R series modules use standard serial port level, so this module can be directly connected with devices with RS485 interface.

3.2 CAN connection

When the GCAN-PLC-326E/R series module is connected to the CAN bus, it only needs to connect CAN_H to CAN_H, and CAN_L to CAN_L to establish communication.

The CAN-bus network adopts a linear topology, and the two farthest terminals of the bus need to be installed with 120Ω terminal resistors; if the number of nodes is greater than 2, the intermediate nodes do not need to be installed with 120Ω terminal resistors. For branch connections, their length should not exceed 3 meters. The connection of the CAN-bus bus is shown in Figure 3.1.

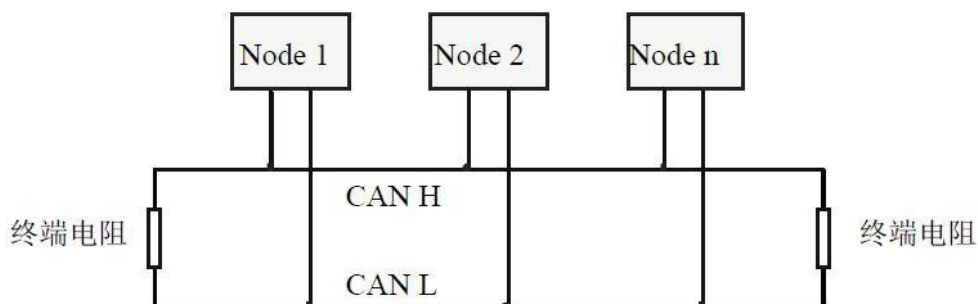

Figure 3.1 CAN-bus network topology

Please note: CAN-bus cable can use ordinary twisted pair or shielded twisted pair. The theoretical maximum communication distance mainly depends on the bus baud rate, and the relationship between the maximum bus length and baud rate is shown in Table 3.1. If the communication distance exceeds 1km, the cross-sectional area of the line should be greater than Φ1.0mm². The specific specification should be determined according to the distance. Normally, it will be appropriately increased with the lengthening of the distance.

Baud rate	Bus length
1 Mbit/s	25m
500 kbit/s	100m
250 kbit/s	250m
125 kbit/s	500m
50 kbit/s	1.0km
20 kbit/s	2.5km
10 kbit/s	5.0km
5 kbit/s	13km

Table 3.1 Baud rate and maximum bus length reference table

3.3 CAN bus terminal resistance

In order to enhance the reliability of CAN communication and eliminate the signal reflection interference of the CAN bus terminal, the two farthest endpoints of the CAN bus network usually need to add terminal matching resistors, as shown in Figure 3.2. The value of the terminal matching resistance is determined by the characteristic impedance of the transmission cable. For example, the characteristic impedance of the twisted pair is 120Ω, and the two endpoints on the bus should also integrate 120Ω termination resistors. If other nodes on the network use different transceivers, the termination resistance must be calculated separately.

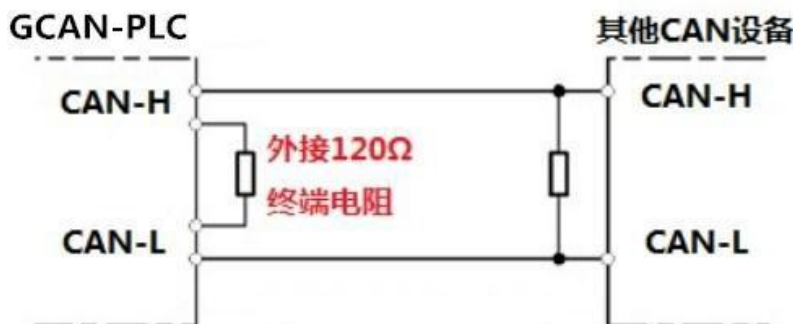

Figure 3.2 Connection between GCAN-PLC-326E/R series modules and other CAN node devices

Please note: the CAN bus of GCAN-PLC-326E/R series modules does not have a 120Ω terminal resistor integrated inside. If the number of nodes is greater than 2, the

intermediate nodes do not need to install 120Ω terminal resistors. When it needs to be used, connect the two ends of the resistor to CAN_H and CAN_L respectively, as shown in Figure 3.2.

4. PLC program running switch and reset button

GSCAN-PLC-326E/R provides 1 program run switch and 1 reset button. After opening the cover shown in the figure, the position of the switches and buttons is shown in Figure 4.1.

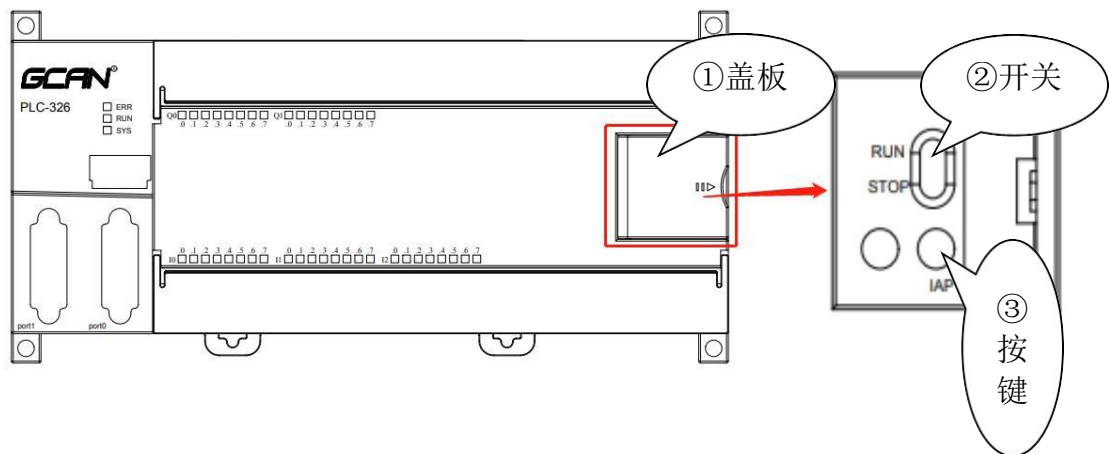

4.1 Physical picture of running switch and reset button

In Figure 4.1:

- ① is the cover plate. The default is off. It can be opened with a slight finger flip.
- ② is the run/stop dial switch.
- ③ is the reset button.

Notice:

1. When the run/stop switch is at the RUN position, it is used to start the PLC program running; when the run/stop button is at the STOP position, it is used to stop the PLC program running.
2. After power on, press and hold the reset button until the ERR light flashes to restore the factory IP address of the PLC: 192.168.1.30.

5. Technical specifications

PLC parameters	
programming environment	OpenPCS
Flash (program memory)	8M bytes
SRAM (data memory)	256k bytes
user data store	2k bytes
Run-time system	Multiple PLC tasks
PLC cycle time	It takes about 0.5ms for 1000 instructions (I/O cycle and GC-bus are not counted)
Program Online Modification	Not support
Programming Language Implementation Standards	IEC 61131-3
programming languages	SFC、LD、FBD、ST、IL
Real Time Clock	built-in
floating point arithmetic	Support
Communication Interface Features	
Communication	1 CAN interface, 1 Ethernet interface, 2 RS485 interfaces
CANopen master/slave	Support
Modbus RTU/TCP master/slave	Support
Electrical parameters	
Power supply	24V DC (-15%/+20%)
Input Current	70mA+ (total GC-bus current) / 1.5A max
Starting current	About 2.5 times continuous current
Recommended fuse capacity	≤10A
electrical isolation	1500 Vrms
Environmental testing	
Working temperature	-40℃~+85℃
Working humidness	95%RH, without condensation
EMC test	EN 55024:2011-09 EN 55022:2011-12
Anti-vibration / impact resistance performance	EN 60068-2-6/EN 60068-2-27/29
Anti-electromagnetic interference/radiation performance	EN 61000-6-2 /EN 61000-6-4
IP grade	IP 20

Sales and service



Shenyang Vhandy Technology Co., Ltd.

Address: Room 401, D11 Block, SISP., Hunnan District, Shenyang, Liaoning, China

E-mail: info@gcanbus.com

Tel/ Whatsapp: +86-13644001762

Website: gcanbus.com